

450  
PSI

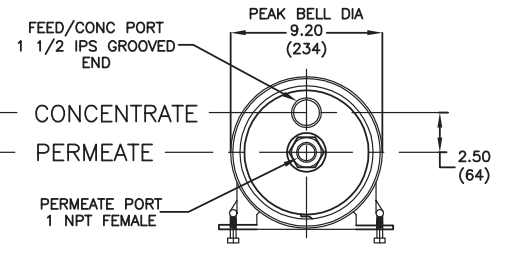

DWG REF	QTY	PART NUMBER	DESCRIPTION	MATERIAL
<b>SHELL</b>				
01	1	99302	SHELL	Filament Wound Epoxy/Glass composite - Head locking grooves integrally wound in place.
<b>HEAD</b>				
02	2	51051	Bearing Plate	6061-T6 As per SB-221
03	2	96003	Sealing Plate	Engineering Thermoplastic.
04	2	50567	Feed/Conc Port	SS-316L As per SA-312
05	2	45090	Port Retainer Set	CF8M Cast SS, Two-piece set
06	2	50569	Permeate Port	Engineering Thermoplastic.
07	2	45066	Port Nut	Engineering Thermoplastic.
08	2	96000	Head Seal	Ethylene Propylene - O Ring.
09	4	45312	Port Seal	Ethylene Propylene - O Ring.
<b>HEAD INTERLOCK</b>				
10	2	47336	Retaining Ring	SS-316 As per SA-479
<b>VESSEL SUPPORT</b>				
11	2"	52169	Saddle	Engineering Thermoplastic.
12	2"	45042	Strap Assy.	304 Stainless Steel - PVC cushion
13	4**	46265	Strap screw.	5/16-18 UNC, 2.5" L, 18-8 Stainless Steel.
<b>ELEMENT INTERFACE</b>				
14	2	A/R	Adapter	Engineering Thermoplastic.
15	4	A/R	PWT Seal	Ethylene Propylene - O - Ring
16	2	52245	Adapter seal	Ethylene Propylene - O - Ring
17	1	45069	Thrust Ring	Engineering Thermoplastic.

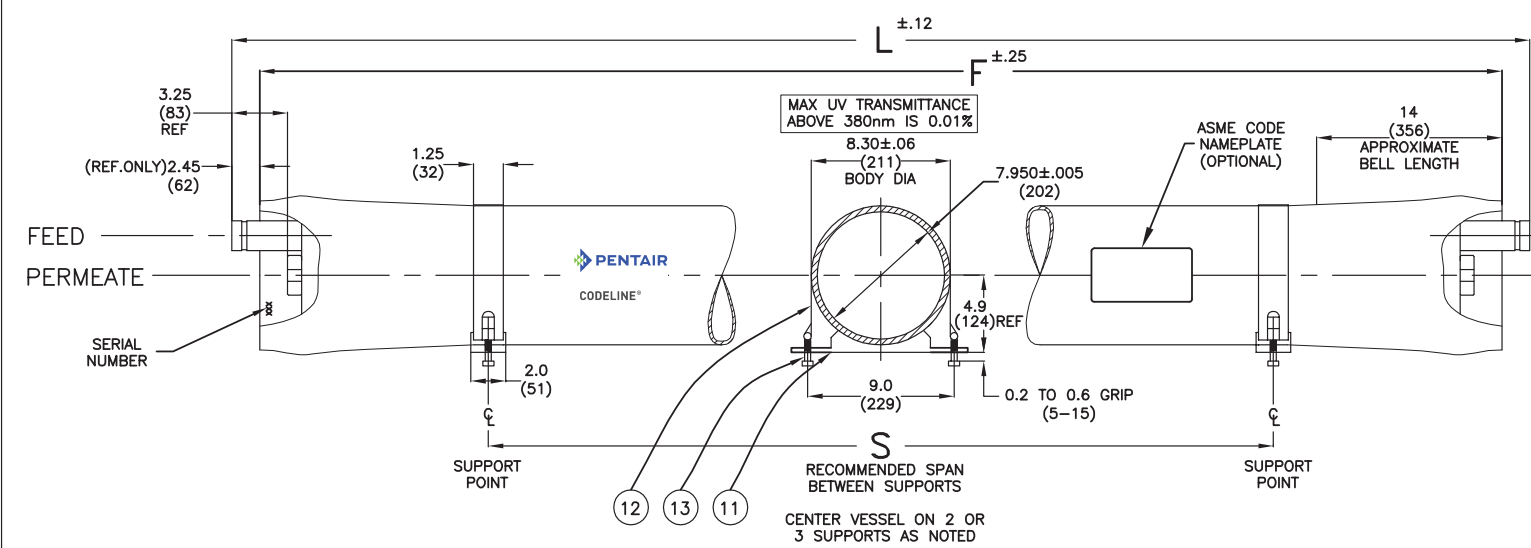
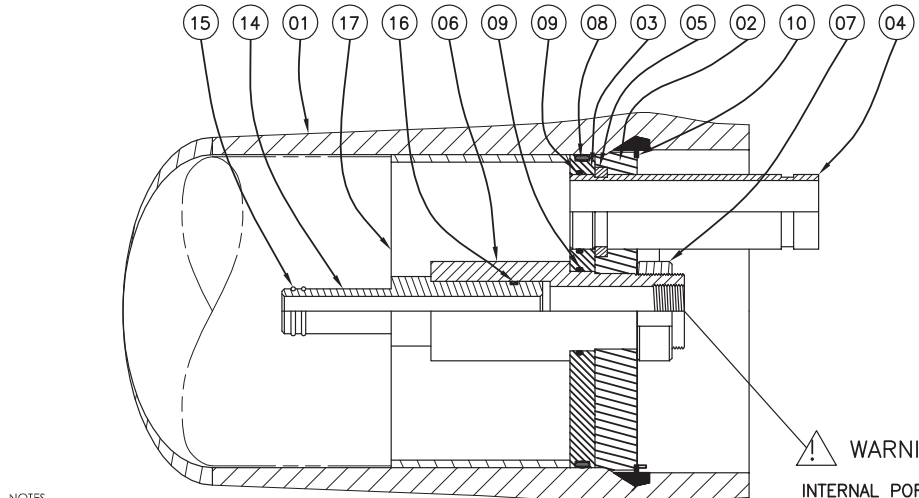

NOTES  
 \*SHELL EXTERIOR COATED WITH WHITE RAL 9003. HIGH GLOSS POLYURETHANE PAINT.  
 \*\*DIMENSION IN INCHES (MM APPROX.)  
 \*NOT TO BE USED FOR CONSTRUCTION UNLESS CERTIFIED  
 \*GENERAL TOLERANCES APPLY. FOR DETAILS CONTACT FACTORY  
 \*L.O.A REFERS TO OVERALL LENGTH OF THE VESSEL  
 \*FC PORT BEARING PLATE & RETAINING RING MATERIALS ARE AS PER STAMPED APPLICABLE ASME EDITION.  
 \*EMPTY WEIGHT REFERS TO SHELL WEIGHT INCLUDING HEAD ASSEMBLIES WITHOUT MEMBRANES.

SECTION THROUGH END CLOSURE  
 ITEM 17 DOWNSTREAM ONLY

WARNING !  
 INTERNAL PORT PRESSURE MUST NOT EXCEED 125 PSI

Shell Length Code	L L.O.A. IN(MM)	S Span IN(MM)	F IN(MM)	Empty Weight LB(KG)
1	63 (1600)	30 X 1 (762)	58.13 (1477)	32 (15)
2	103 (2616)	70 X 1 (1778)	98.13 (2493)	47 (21)
3	143 (3632)	110 X 1 (2794)	138.13 (3509)	61 (28)
4	183 (4648)	75 X 2 (1905)	178.13 (4525)	76 (34)
5	223 (5664)	95 X 2 (2413)	218.13 (5541)	90 (41)
6	263 (6680)	115 X 2 (2921)	258.13 (6557)	105 (48)
7	303 (7696)	135 X 2 (3429)	298.13 (7573)	119 (54)
8	343 (8712)	155 X 2 (3937)	338.13 (8589)	134 (61)

**PENTAIR**  
**CODELINE®**

**MODEL 80E45**  
**MEMBRANE HOUSING**

DRAWN DATE	KK 10APR15	ECN 4624				
CHECKED DATE	KPS 10APR15	DATE 26DEC17				
APPROVED DATE	MKS 10APR15	SCALE NONE	SHEET 1 OF 2	SIZE B	NUMBER 99112	REV T

\*3 & \*\*6 Each Furnished With Length code 4, 5, 6 & 7.

**RATING:**

DESIGN PRESSURE.....450 PSI  
 (3.1 MPa)  
 MAX. OPERATING TEMP.....120°F  
 (49°C)  
 MIN. OPERATING TEMP.....20°F  
 (-7°C)  
 FACTORY TEST PRESSURE.....CE / ASME  
 675 PSI / 495 PSI  
 (4.65Mpa) / (3.41 MPa)  
 BURST PRESSURE.....2700 PSI  
 (18.62 MPa)

**INTENDED USE:**

The CodeLine Model 80E45 Fiberglass RO Pressure Vessel is designed for continuous, long-term use as housing for reverse osmosis membrane elements to desalt typical brackish waters at pressures up to 450 psi. Any make of eight-inch nominal diameter spiral-wound element is easily accommodated; the appropriate interfacing hardware for the element specified is furnished with the vessel.

The CodeLine Model 80E45 must be installed operated and maintained in accordance with the listed precautions and good industrial practice to assure safe operation over a long service life.

The CodeLine Model 80E45 is designed in accordance with the engineering standards of the Boiler and Pressure Vessel Code of the American Society of Mechanical Engineers (ASME Code) Section X. At small additional cost, vessels can be inspected during construction by an ASME Authorized inspector and ASME Code stamped.

The high performance reinforced plastic shell must be allowed to expand under pressure; undue restraint at support points or piping connections can cause leaks to develop in the shell. The end closure, incorporating close fitting, interlocking metal components, must be kept dry and free of corrosion; deterioration can lead to catastrophic mechanical failure of the head.

The end closures, incorporating close-fitting, interlocking metal components, must be kept dry and free from corrosion; deterioration can lead to catastrophic mechanical failure of the heads.

Pentair will assist the purchaser in determining the suitability of this standard vessel for their specific operating conditions. The final determination however, including evaluation of the standard material of construction for compatibility with the specific corrosive environment, shall be the responsibility of the purchaser.

Specifications are subject to change without notice.

**PRECAUTIONS:**

DO...read, understand and follow all instructions; failure to take every precaution will void warranty and may result in vessel failure  
 DO...mount the shell on horizontal members at span "S" using complaint vessel supports furnished; tighten hold down straps just snug  
 DO...provide overpressure protection for vessel set at not more than 105% of design pressure  
 DO...inspect end closures regularly; replace components that have deteriorated and correct causes of corrosion

DO NOT... make rigid piping connections to ports or clamp vessel in any way that resists growth of fiberglass shell under pressure; ΔDIA = 0.02 in. (0.5mm) and ΔL = 0.2 in. (5mm) for a length code -6 vessel

DO NOT... hang piping manifolds from ports or use vessel in any way to support other components; branch connection piping may be simply supported between the header and port; maximum weight of branch piping; feed/concentrate – 16 lbs (7 kg); permeate – 8 lbs (4 kg)

DO NOT... operate vessel at pressures and temperatures in excess of its rating

DO NOT... operate vessel without permeate ports internally connected with a complete set of elements and interconnecting hardware

DO NOT... operate vessel with permeate pressure in excess of 125 psi at 120°F (0.86 MPa @ 49°C)

DO NOT... overtighten the connection to the permeate port (hand-tighten plus one-quarter turn, check for leaks)

DO NOT... tolerate leaks or allow end closures to be routinely wetted in any way

DO NOT... pressurize vessel until double-checking to verify that the retaining ring is completely inside the groove

DO NOT... work on any component until first verifying that pressure is relieved from vessel

DO NOT... operate outside the pH range 3-11

**ORDERING:**

Using the chart below, please check the features you require and fax them with your purchase order to our customer service department for expedited processing.  
 For optional materials and/or features not listed below, please consult factory for pricing and availability.

Please note that we require your membrane brand and model number when ordering. If this information is not initially available, you may provide it at a later date by checking the appropriate box below.

**VESSEL LENGTH CODE – please check one**

MODEL 80E45  -1  -2  -3  -4  -5  -6  -7  -8

**MEMBRANE BRAND AND MODEL – please check one and fill in information**

Please supply adapters for the following membrane brand and specific model  
 Brand \_\_\_\_\_ Model \_\_\_\_\_

**CERTIFICATION REQUIRED**

- ASME Stamped and National Board Registered (please consult factory for pricing) (ASME Section X)
- CE Marked
- Standard, Certified by Pentair.

**EXTERIOR FINISH – please check one**

- Standard – white high-gloss polyurethane coating.
- Option – optional colors are available for 50 or more vessels per order. Call factory for pricing details.

**MATERIAL OPTIONS**

- Standard – All materials as per drawing 99112 on the first page.
- Customer specified materials: - (Please consult the factory, as these options will affect pricing and vessel lead-time.)

For complete information on proper use of this vessel please refer to the 80E series USER'S GUIDE Bulletin 523004.