

RATING:

DESIGN PRESSURE.....1200 PSIG
(8.27 MPa)
MAX. OPERATING TEMP.....150°F
(66°C)
MIN. OPERATING TEMP..... 20°F
(-7°C)
FACTORY TEST PRESSURE.....CE / ASME
1800 PSIG / 1320 PSIG
(12.41 MPa)/(9.10 MPa)
QUALIFICATION PRESSURE7200 PSI
(49.64 MPa)

INTENDED USE:

The CodeLine 80S120 Fiberglass RO Pressure Vessel is designed for continuous, long term use as housing for reverse osmosis membrane elements to desalt typical sea waters at pressures up to 1200 psi. Any make of eight-inch nominal diameter spiral-wound element is easily accommodated; the appropriate interfacing hardware for the element specified is furnished with the vessel.

The CodeLine 80S120 is designed in accordance with the engineering standards of the Boiler and Pressure Vessel Code of the American Society of Mechanical Engineers (ASME) as per Section X. At small additional cost vessels can be inspected during construction by an ASME Authorized Inspector and ASME Code stamped.

The CodeLine 80S120 must be installed, operated and maintained in accordance with the listed precautions and good industrial practice to assure safe operation over a long service life.

The high performance Filament wound FRP shell must be allowed to expand under pressure; undue restraint at support points or piping connections can cause leaks to develop in the shell. This side-ported vessel requires special precautions in mounting and connection to piping so that the vessel will not be subjected to excessive stress due to bending moments acting at the side openings in the fiberglass shell. The end closure, incorporating close fitting, interlocking metal components, must be kept dry and free of corrosion; deterioration can lead to catastrophic mechanical failure of the head.

Pentair will assist the purchaser in determining the suitability of this standard vessel for their specific operating conditions. The final determination however, including evaluation of the standard material of construction for compatibility with the specific corrosive environment, shall be the responsibility of the purchaser. Alternate materials with enhanced corrosion resistance are available on special order.

Specifications are subject to change without notice.

PRECAUTIONS:

- DO...read, understand and follow all instructions; failure to take every precaution will void warranty and may result in vessel failure
- DO...mount the shell on horizontal members at span "S" using compliant vessel supports furnished; Shim saddles if required. Tighten hold down straps just snug
- DO...align and center side ports with the manifold header. Correct, causes of misalignment in a row of vessels connected to the same header
- DO...use flexible type IPS grooved-end pipe couplings, at side ports; allow full, 0.125 inch gap between port and piping, and position piping to maximize flexibility of connection.
- DO...provide flexibility in, and support for piping manifolds so that vessel can grow in length under pressure without undue restraint; provide additional flexible joints in large pipes leading to manifold header.
- DO...provide overpressure protection for vessel set at not more than 105% of design pressure
- DO...inspect end closures regularly; replace components that have deteriorated and correct causes of corrosion
- DO... Lubricate seals sparingly, using nonpetroleum Based lubricants, i.e. Parker Super O-lube®, Glycerin or suitable silicone based lubricants.
- DO NOT...work on any component until first verifying that pressure is relieved from vessel
- DO NOT...make rigid piping connections to ports or clamp vessel in any way that resists growth of fiberglass shell under pressure;
***ΔDIA = 0.015 in. (0.4mm) and
***ΔL = 0.2 in. (6mm) for a length code –8 vessel
- DO NOT... hang piping manifolds from ports or use vessel in any way to support other components
- DO NOT...tighten Permeate Port connection more than one turn past hand tight
- DO NOT... operate vessel without connecting both Permeate Ports internally to complete set of elements or otherwise plug ports internally so that external piping connection is not subjected to feed pressure
- DO NOT...install Spacer on downstream end of vessel
- DO NOT...operate vessel without Thrust Cone installed downstream
- DO NOT...pressurize vessel until double-checking to verify that the Locking Ring is in place and fully seated.
- DO NOT...operate vessel at pressure and temperature in excess of its rating.
- DO NOT...operate vessel with permeate pressure in excess of 125 psi at 150°F (0.86 Mpa at 66°C).
- DO NOT...tolerate leaks or allow end closures to be routinely wetted in any way
- DO NOT...operate outside the pH range 3-11.

For complete information on proper use of the vessel please refer to the 80S Series USER'S GUIDE 94182

ORDERING:

Using the chart below, please check the features you require

VESSEL LENGTH CODE – please check one

MODEL 80S120 -1 -2 -3 -4 -5 -6 -7 -8

MEMBRANE BRAND AND MODEL

Please supply adapters for the following membrane brand and specific model
Brand _____ Model _____

CERTIFICATION REQUIRED

- Hydro testing at 1.1 times the design pressure.
 - ASME Stamped and National Board Registered.
 - In compliance with the ASME Sec X but not Code Stamped.
- Hydro testing at 1.5 times the design pressure.
 - CE Marked Standard.
 - Certified by Pentair.

PERMEATE PORT SELECTION

Serial Number End

Size of the Permeate Port 1" 1.25" 1.5"
Type of Connection FNPT MNPT BSPTM BSPTF IPS GROOVED SANITARY
Material of Construction Noryl SS316L Zeron 100

Non Serial Number End

Size of the Permeate Port 1" 1.25" 1.5"
Type of Connection FNPT MNPT BSPTM BSPTF IPS GROOVED SANITARY
Material of Construction Noryl SS316L Zeron 100

Note:

- Standard offering is 1.0" FNPT in Noryl.
- 1.25" & 1.5" BSPTF, 1.25" & 1.5" FNPT and 1.25" SANITARY connections cannot be offered
- Sanitary permeate port cannot be offered in Noryl

STRAP ASSEMBLY

Standard SS304 Optional SS316 Optional SS316L

FEED/CONCENTRATE PORT SELECTION

Material of Construction STD Super Duplex SS (CD3MWCuN)
 Optional - CE3MN * (Cannot be offered for ASME Stamped vessels)

Configuration Standard – CD3MWCuN 1D5D
 Optional –Multi port: (Refer SPEC.SHEET/PM/1.5"-3" for Multi ports selection).
1.5", 2", 2.5" Ports not available in 90° configurations.

Serial number end
Opposite end

BEARING PLATE MATERIAL

Standard – 6061 T6 Aluminium
 Optional – Stainless Steel 316L

ADAPTER KITS	
UP STREAM	DOWN STREAM

PORT SIZE CODE	
D	1½" GROOVED END
E	2" GROOVED END
F	2½" GROOVED END

Note: Please refer to 99376 for sanitary details and refer page-3 for optional Part numbers.

4

3

2

1

BEARING PLATE PART NUMBERS		
PERMEATE PORT SIZE	ALUMINIUM	SS F316L ###
1.0"/1.25"	96158	96475
1.5"	96343	97370

SEALING PLATE PART NUMBERS	
Standard used for Aluminium BP	96160
Optional used for SS316L BP	96477

PERM PORT RETAINER RING & PORT NUT PART NUMBERS		
1.0" / 1.25"	Standard Port nut	45066
1.5"	Port Retainer Ring	45247

STRAP ASSEMBLY PART NUMBERS		
SS304	SS316	SS316L
45042	46926+	94371+

F/C PORT & SEAL PART NUMBER			
SIZE	***CD3MWCuN	**CE3MN	SEAL
1.5"	96469	97375	96077
2.0"	96645	97376	96078
2.5"	96385	97377	96079

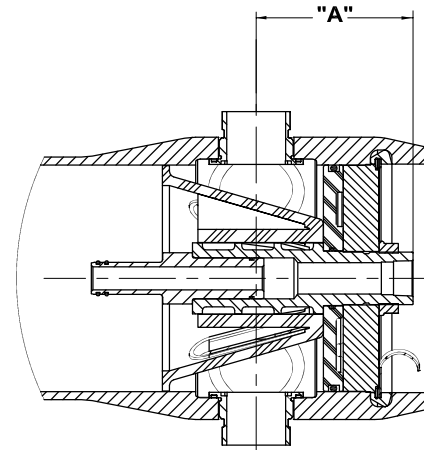

SECTION THROUGH END CLOSURE

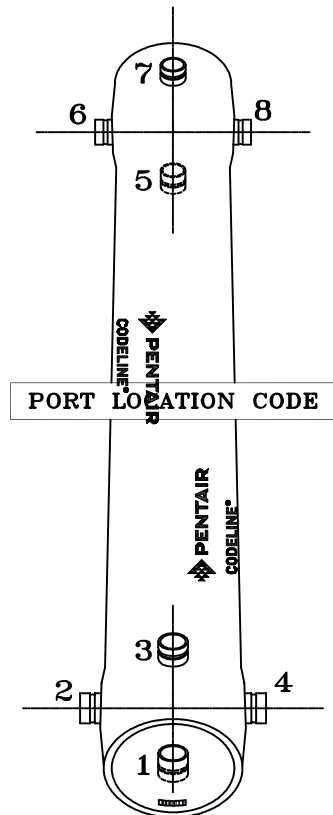

Serial Number End

CODELINE BODY LABELS ARE PLACED AT 90° TO SERIAL NUMBER END AND AT 270° ON THE OPPOSITE SIDE END

PERMEATE PORT PART NUMBERS & PERMPORT TO F/C PORT OFFSET DISTANCE											
SIZE	MATERIAL	FNPT		MNPT		BSPTF		BSPTM		IPS GROOVED	
		PART NUMBER	DIM "A"	PART NUMBER	DIM "A"	PART NUMBER	DIM "A"	PART NUMBER	DIM "A"	PART NUMBER	DIM "A"
1.0"	NORYL	96162	5.5	97659	6.5	96301	5.5	97660	6.5	97661	6.8
	SS316L ##	96752	5.5	97347	6.5	97351	5.5	97355	6.5	97322	6.8
	#ZERON 100	97349	5.5	97348	6.5	97352	5.5	97356	6.5	97293	6.8
1.25"	NORYL	NA	NA	97655	6.5	NA	NA	97360	6.5	97662	6.8
	SS316L ##	NA	NA	96487	6.5	NA	NA	97362	6.5	97311	6.8
	#ZERON 100	NA	NA	97359	6.5	NA	NA	97363	6.5	97365	6.8
1.5"	NORYL	NA	NA	97663	6.1	NA	NA	97369	6.1	97656	6.7
	SS316L ##	NA	NA	97368	6.1	NA	NA	97371	6.1	97449	6.7
	#ZERON 100	NA	NA	97292	6.1	NA	NA	97372	6.1	97374	6.7

NOTES

- " DIMENSION IN INCHES (MM APPROX.)
 ** GRADE CE3MN AS PER SA-995 (UNS-J93404)
 CE3MN cannot be offered for ASME Stamped vessels.
 *** GRADE CD3MWCuN AS PER SA-995 (J 93380)
 # GRADE ZERON 100 AS PER SA-479
 ## GRADE SS-316L AS PER SA-479
 ### GRADE SS-F316L AS PER SA-182
 + OPTIONAL STRAP ASSEMBLY WITH SS-316 & 316L SHALL BE SUPPLIED AS PER METRIC STANDARDS

DRAWN	PDM 27 JUN 11	MODEL - 80S120 MEMBRANE HOUSING			
CHECKED	RD 27 JUN 11	DATE 14DEC17	DWG. NO. 99164	REV. S	
APPROVED	RM 27 JUN 11	ECN 4624	SCALE NONE	SIZE A3	SHEET 3 OF 3

4

3

2

1